

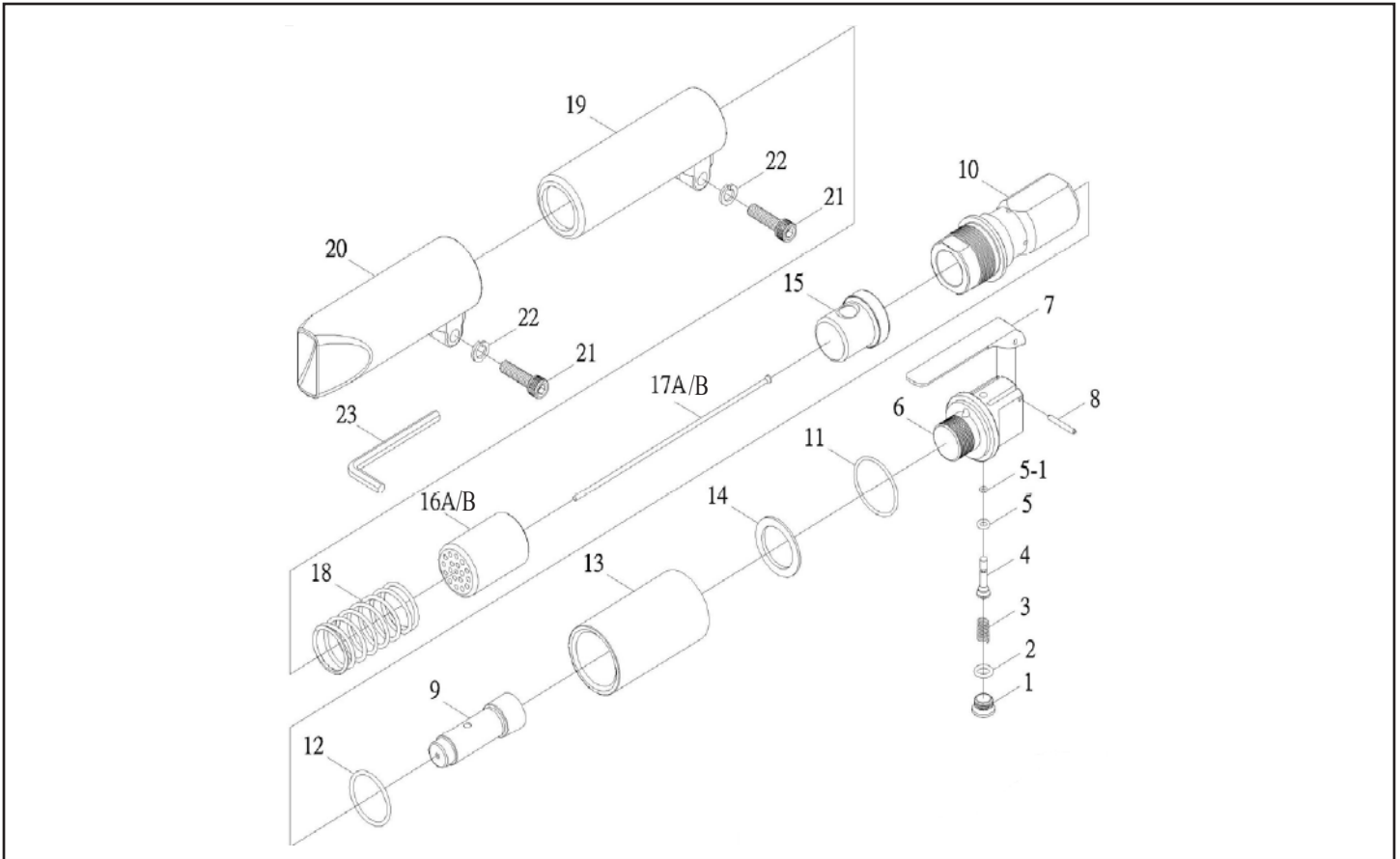

MICHIGAN PNEUMATIC TOOL, INC.

MP-2B Needle Scaler



Index	Part No.	Description	Qty.
1	2B-01	Valve Cap	1
2	2B-02	O-Ring Valve Cap	1
3	2B-03	Valve Spring	1
4	2B-04	Valve Stem	1
5	2B-05	O-Ring Valve Seat	1
5-1	2B-05-1	O-Ring	1
6	2B-06	Valve Body	1
7	2B-07	Throttle Lever	1
8	2B-08	Roll Pin	1
9	2B-09	Piston	1
10	2B-10	Cylinder	1
11	2B-11	O-Ring	1
12	2B-12	O-Ring	1

Index	Part No.	Description	Qty.
13	2B-13	Piston Sleeve	1
14	2B-14	Clamp Washer	1
15	2B-15	Anvil	1
16A	2B-16A	Needle Holder 3mm	1
16B	2B-16B	Needle Holder 2mm	1
17A	3mm19	3mm Needle Set (19 pc./set)	1
17B	2mm29	2mm Needle Set (29 pc./set)	1
18	2B-18	Spring Compression	1
19	2B-19	Intermediate Tube	1
20	2B-20	Front Tube	1
21	2B-21	Cap Head Screw	2
22	2B-22	Washer	2
23	2B-23	Hex Wrench	1