

Instructions And Maintenance Manual AVK Power Installation Tooling

For Installing The Following AVK Threaded Inserts—

AL SERIES INSERTS • AK SERIES INSERTS • AO SERIES INSERTS
AT SERIES INSERTS • AW SERIES INSERTS • AH SERIES INSERTS
AP SERIES INSERTS • AR SERIES INSERTS



INDEX

AIR LINE SET UP.....	Page 2
LUBRICATION.....	2
OBTAINING PROPER AIR PRESSURE.....	2-3
METHOD OF INSTALLATION.....	3
CONVERSION CAPABILITIES.....	4
ADAPTION KIT PART NUMBERS.....	4-5
THREAD ADAPTION KIT CHANGE OVER.....	5-6
TROUBLE SHOOTING.....	7
MAINTENANCE.....	8-9
PARTS AND ASSEMBLY BREAKDOWNS....	9-12



AVK INDUSTRIAL PRODUCTS

A PCC Company

THREADED INSERTS FOR INDUSTRY

AVK INDUSTRIAL THREADED INSERTS

INTRODUCTION

Read manual before operating tool.

You now own the finest insert installation tool on the market today. These durable tools provide many years of trouble free operation if you will simply follow the instructions in this manual.

Prior to use, certain checks must be made. This tool requires the proper air line setup, lubrication, and air pressure to set the desired inserts.

AIR LINE SET UP

Every ARO Air Tool is designed and built to yield the longest possible useful life, with a minimum amount of servicing. Since an air tool is a precision machine whose working parts mate with close tolerances, it should receive the same reasonable care as any other machine tool. Here are a few simple practices that will keep your ARO Air Tool in top operating condition.

KEEP AIR SUPPLY CLEAN. All compressed air carries varying amounts of dust, scale, moisture and other foreign matter that should be removed by proper filtering. Failure to keep air supply clean will result in excessive wear on working parts. Therefore, we recommend the installation of an air line filter. If your tool is equipped with a built-in air strainer, remove and clean the strainer periodically. Always blowout the air hose before attaching to tool.

LUBRICATION

USE AIR LINE LUBRICATOR. Air tool motors operate at extremely high speeds, and must have proper oil lubrication. An air line lubricator should be installed and oil supply properly regulated. Your ARO Distributor can furnish the correct combination air line filter and oiler. Some units can service up to three tools simultaneously. As a further precaution, put a few drops of light oil in air inlet of tool before attaching tool to air line for the first time.

RECOMMENDED LUBRICANTS: Spindle Oil 29665 (1 qt. container) for oiler and air inlet.

FILTERED AND OILED AIR will allow the tool to operate more efficiently and yield a longer life to operating parts and mechanisms. A line filter capable of filtering particles larger than 50 microns should be used with a line oiler.

FILTER-REGULATOR-OILER combination (F-R-L) Model 28231-810 is recommended for use with this Air Tool. The capacity of the individual Filter-Oiler is adequate to provide clean (40 micron), oiled and regulated air for the tool. **AIR CONSUMPTION:** Approximately 25 SCFM.

RECOMMENDED HOSE SIZE: 5/16" nominal inside diameter.

OBTAINING PROPER AIR PRESSURES

AVK's power installation tools have been designed to operate at the listed "Dynamic" P. S.I. ratings at the air inlet of the tool. Even though the in-line pressure gage may show the proper pressure, the use of long hoses, quick-disconnects and other couplers between the gage and the tool can adversely affect the tool's performance. A simple test, so you may correlate our required P. S.I. setting with your set-up is:

1. Connect a 1/4" short pipe nipple into the tool's air inlet.
2. Screw a 1/4" pipe tee onto the pipe nipple and put an air gage into the upright leg of the pipe tee.
3. Connect the air supply to the pipe tee using the actual hose, fittings, couplers or connectors that will be used.
4. Now, check the P.S.I. on the test gage at the air tool inlet with the tool running. Adjust, as necessary, the air pressure regulator so that the P.S.I. required is shown on the test gage. Note the reading on the in-line pressure gage. It will probably read a higher P. S.I. than the gage at the tool. The figure on the in-line gage is the "Adjusted Dynamic P.S.I." Use this figure when using the tool in that location with that hose set-up.
5. Remove tee, nipple and gage, connect air supply directly to tool and begin production.

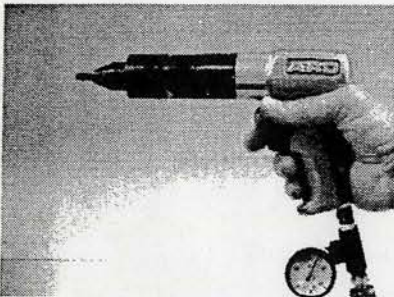

Test dynamic air pressure readings at the location where the tool is to be operated* (Instructions, Pg. 3)

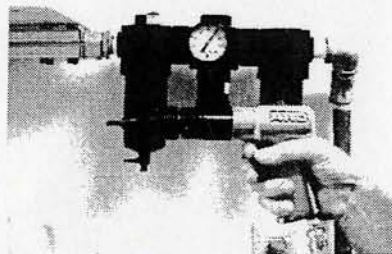

Adjust the in-line air pressure regulator so that dynamic pressure is in accordance with AVK's power tool specs at the air tool inlet.

PROPER AIR DIFFERENT INSERTS

It is necessary to use the appropriate air pressure and RPM tool to set a particular insert. Here's how to insure the proper set up:

1. Identify the TYPE of insert. (i.e. AH-AL-AK-AO-AT etc.)
2. Identify the insert material. (i.e. steel, brass etc.)
3. Identify the thread size. (i.e. #10-32" 1/4-20, M6 etc.)
4. Refer to the following table. Find the correct material & insert type heading and come down to the PSI & RPM line adjacent to the thread size. Use this pressure setting and tool RPM.

PSI AND RPM CHART

INSERT MAT'L	STEEL- BRASS				STAINLESS		ALUMINUM				*MONEL	
INSERT TYPE	AH-AK-AL-AO-AP		AT-AW		AT		AK-AL		AT		AK-AL	
THREAD SIZE	PSI	TOOL RPM	PSI	TOOL RPM	PSI	TOOL RPM	PSI	TOOL RPM	PSI	TOOL RPM	PSI	TOOL RPM
#4-40	-	-	36-40	3000	45-50	3000	-	-	40-45	3000	60-90	3000
#6-32	75-90	3000	70-80	3000	65-70	3000	60-80	3000	60-80	3000	60-90	3000
#8-32	75-90	3000	60-85	3000	85-90	3000	60-80	3000	70-80	3000	60-90	3000
#10-32	60-80	1500	60-85	1500	80-90	1500	70-90	1500	60-80	3000	70-100	900
#10-24	60-80	1500	70-95	1500	80-90	1500	70-90	1500	60-80	3000	70-100	900
1/4-20	70-90	900	70-95	1500	75-85	600	70-95	900	60-90	1500	80-100	600
1/4-28	80-110	900	80-100	1500	75-85	600	70-95	900	60-90	1500	80-100	600
5/16-18	80-110	600	80-100	600	90-100	600	80-110	600	80-100	600	60-90	300
5/16-24	80-110	600	90-110	600	90-100	600	80-110	600	80-100	600	60-90	300
3/8-16	80-110	600	90-110	600	90-110	600	90-110	600	80-110	600	60-90	300
3/8-24	80-110	600	95-110	600	90-110	600	90-110	600	80-110	600	60-90	300
1/2-13	80-110	350	95-110	350	-	-	-	-	-	-	-	-
1/2-20	80-110	350	95-110	350	-	-	-	-	-	-	-	-
M3	-	-	36-40	3000	45-50	3000	-	-	36-40	3000	-	-
M4	70-80	3000	60-85	3000	80-90	3000	60-80	3000	70-80	3000	60-90	3000
M5	60-80	1500	60-85	1500	80-90	1500	70-90	1500	60-80	3000	70-100	900
M6	70-90	900	70-95	1500	75-85	600	70-95	900	60-80	1500	80-100	600
M8	80-110	600	80-100	600	95-110	600	80-110	600	80-100	600	60-90	300
M10	80-110	600	90-110	600	95-110	600	80-110	600	80-110	600	60-90	300
M12	80-110	350	95-110	350	-	-	-	-	-	-	-	-

NOTE: 1. USE LOWER LISTED AIR PRESSURE WHEN INSTALLATION IS IN LOWER PART OF GRIP RANGE AND HIGHER LISTED AIR PRESSURE IN HIGHER PART OF GRIP RANGE.

2. CONTACT FACTORY FOR PSI SETTINGS NOT LISTED.

*3. LUBRICATE MANDREL OFTEN-EVERY 2 OR 3 INSERTS.

METHOD OF INSTALLATION

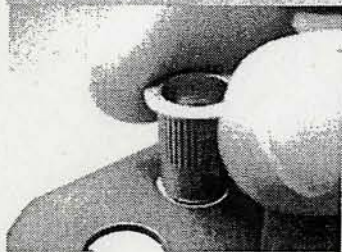

1. Place the insert into the prepared hole. Insert tool mandrel into insert, engaging the thread. Not recommended with A-H Series.

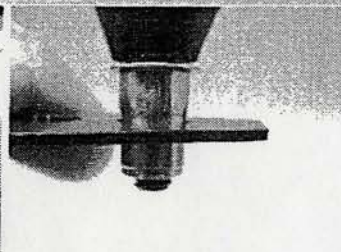

2. For the A-H Series we recommend threading the tool mandrel then insert into hole.



3. Keep the tool square to the work piece and depress the "top" portion of the trigger until tool stalls.

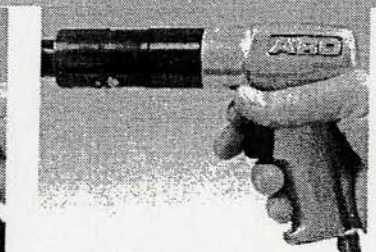

4. After tool stalls, reverse the tool by depressing the "bottom" of the trigger. Removal of the tool completes the installation.

CONVERSION CAPABILITIES

Power ranges have been carefully selected to assure proper insert installation. One RPM tool may be used to set various thread size inserts as shown in the PSI and RPM chart. Be sure to match the RPM of the tool to the insert thread size, and insert material.

Complete tool adaption kit (CTA) is that portion of the tool that is screwed onto the air motor to make a AVK insert tool. (Left hand thread)

Thread adaption kit, (TAK) is the portion of the CTA that is disengaged by activation of the "quick release mechanism". Note the following illustrations.

A-H, A-K, A-L, A-O AND A-P SERIES INSERT THREAD ADAPTION KITS AND COMPONENT PART NUMBERS.

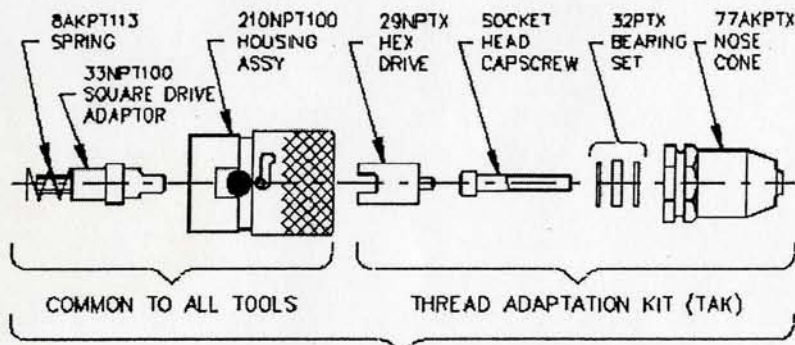

COMPLETE TOOL ADAPTION (CTA)

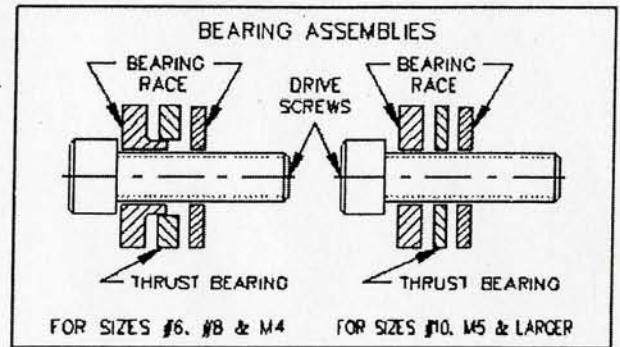

*Nozzle design for AH,AK,AL,AO and AP Series Insert Installation - Do not use for AT,AW or RN Series insert installation.

THREAD SIZE	CTA PART NO.	TAK PART NO.	HEX DRIVE	*SOCKET HEAD CAP SCREW	BEARING SET	NOSE CONE
#6-32	AKPT632 CTA	AKPT632 TAK	29NPT22	#6-32 x 1 1/2"	32PT1	77AKPT6
#8-32	AKPT832 CTA	AKPT832 TAK	29NPT23	#8-32 x 1 1/2"	32PT2	77AKPT8
M4x0.7	AKPT470 CTA	AKPT470 TAK	29NPT24	M4 x 40mm	32PT3	77AKPT470
#10-24	AKPT1024 CTA	AKPT1024 TAK	29NPT4	#10-24 x 1 3/4"	32PT4	77AKPT10
#10-32	AKPT1032 CTA	AKPT1032 TAK	29NPT4	#10-632 x 1 3/4"	32PT4	77AKPT10
M5x0.8	AKPT580 CTA	AKPT580 TAK	29NPT10	M5 x 45mm	32PT4	77AKPT580
1/4-20	AKPT420 CTA	AKPT420 TAK	29NPT5	1/4-20 x 1 1/2"	32PT5	77AKPT250
1/4-28	AKPT428 CTA	AKPT428 TAK	29NPT5	1/4-28 x 1 1/2"	32PT5	77AKPT250
M6x1.0	AKPT610 CTA	AKPT610 TAK	29NPT11	M6 x 40mm	32PT6	77AKPT610
5/16-18	AKPT518 CTA	AKPT518 TAK	29NPT6	5/16-18 x 2"	32PT7	77AKPT3125
5/16-24	AKPT524 CTA	AKPT524 TAK	29NPT6	5/16-24 x 2"	32PT7	77AKPT3125
M8x1.25	AKPT8125 CTA	AKPT8125 TAK	29NPT12	M8 x 50mm	32PT7	77AKPT8125
3/8-16	AKPT616 CTA	AKPT616 TAK	29NPT7	3/8-16 x 2"	32PT8	77AKPT375
3/8-24	AKPT624 CTA	AKPT624 TAK	29NPT7	3/8-24 x 2"	32PT8	77AKPT375
M10x1.5	AKPT1015 CTA	AKPT1015 TAK	29NPT25	M10 x 50mm	32PT10	77AKPT1015
1/2-13	AKPT813 CTA	NOT AVAILABLE	29NPT26	1/2-13 x 2500	30NPT500	77AKPT500
1/2-20	AKPT820 CTA	NOT AVAILABLE	29NPT26	1/2-20 x 2500	30NPT500	77AKPT500
M12x1.75	AKPT12175 CTA	NOT AVAILABLE	29NPT27	M12 x 60mm	30NPT500	77AKPTM12

*NOTE: Use high quality alloy steel socket head cap screws such as "UNBRAKO®" by SPS

A-T SERIES AND A-W SERIES INSERT THREAD ADAPTION KITS AND COMPONENT PART NUMBERS

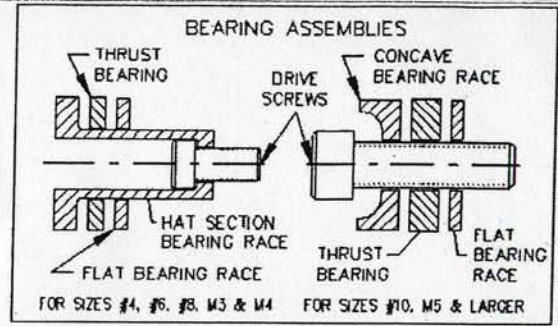
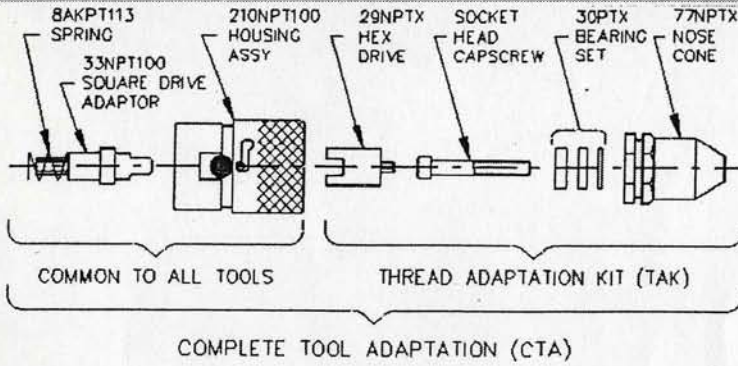

*Knurl only design for AT & AW insert installation
Do not use for AK, AH, AL, AO or AP insert installation.

THREAD SIZE	CTA PART NO.	TAK PART NO.	HEX DRIVE	*SOCKET HEAD CAP SCREW	BEARING SET	NOSE CONE
4-40	NPT440 CTA	NPT440 TAK	29NPT1	4-40 x 3/4"	30NPT4	77NPT4
M3	NPT350 CTA	NPT350 TAK	29NPT8	M3 x 20mm	30NPTM3	77NPTM3
#6-32	NPT632 CTA	NPT632 TAK	29NPT2	#6-32 x 3/4"	30NPT6	77NPT6
#8-32	NPT832 CTA	NPT832 TAK	29NPT3	#8-32 x 3/4"	30NPT8	77NPT8
M4	NPT470 CTA	NPT470 TAK	29NPT9	M4 x 20mm	30NPTM4	77NPTM4
#10-24	NPT1024 CTA	NPT1024 TAK	29NPT4	#10-24 x 1 1/2"	30NPT10	77NPT10
#10-32	NPT1032 CTA	NPT1032 TAK	29NPT4	#10-632 x 1 1/2"	30NPT10	77NPT10
M5	NPT580 CTA	NPT580 TAK	29NPT10	M5 x 40mm	30NPTM5	77NPTM5
1/4-20	NPT420 CTA	NPT420 TAK	29NPT5	1/4-20 x 1 1/4"	30NPT250	77NPT250
1/4-28	NPT428 CTA	NPT428 TAK	29NPT5	1/4-28 x 1 1/4"	30NPT250	77NPT250
M6	NPT610 CTA	NPT610 TAK	29NPT11	M6 x 35mm	30NPTM6	77NPTM6
5/16-18	NPT518 CTA	NPT518 TAK	29NPT6	5/16-18 x 1 3/4"	30NPT3125	77NPT3125
5/16-24	NPT524 CTA	NPT524 TAK	29NPT6	5/16-24 x 1 3/4"	30NPT3125	77NPT3125
M8	NPT8125 CTA	NPT8125 TAK	29NPT12	M8 x 45mm	30NPTM8	77NPTM8
3/8-16	NPT616 CTA	NPT616 TAK	29NPT7	3/8-16 x 1 3/4"	30NPT375	77NPT375
3/8-24	NPT624 CTA	NPT624 TAK	29NPT7	3/8-24 x 1 3/4"	30NPT375	77NPT375
M10	NPT1015 CTA	NPT1015 TAK	29NPT25	M10 x 45mm	30NPTM10	77NPTM10
1/2-13	NPT813 CTA	NOT AVAILABLE	29NPT26	1/2-13 x 2"	30NPT500	77NPT500
1/2-20	NPT820 CTA	NOT AVAILABLE	29NPT26	1/2-20 x 2"	30NPT500	77NPT500
M12	NPT12175 CTA	NOT AVAILABLE	29NPT27	M12 x 50mm	30NPT500	77NPTM12

*NOTE: Use high quality alloy steel socket head cap screws such as "UNBRAKO®" by SPS

THREAD CHANGEOVER & DISASSEMBLY FOR SERVICE

THREAD CHANGEOVER USING A THREAD ADAPTION KIT (TAK)

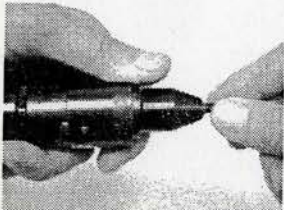

Push button in and push back on locking ring and rotate to "unlocked" position and push to release TAK.

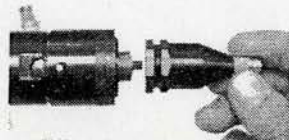

Using the drive screw, pull nose assembly out of housing.

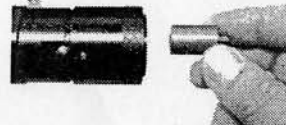

Pull out hex drive

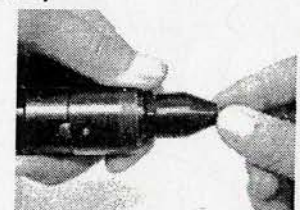

New Housing
Drop in new drive, then nose assembly
Push button in and push back on locking ring, then push TAK into tool.
Release locking ring and nosepiece. Rotate locking ring to "locked" position.

A-R SERIES INSERT THREAD ADAPTION KITS AND COMPONENT PART NUMBERS

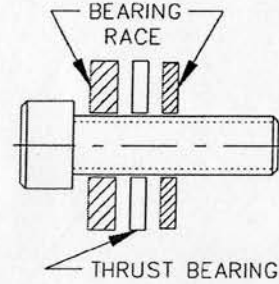
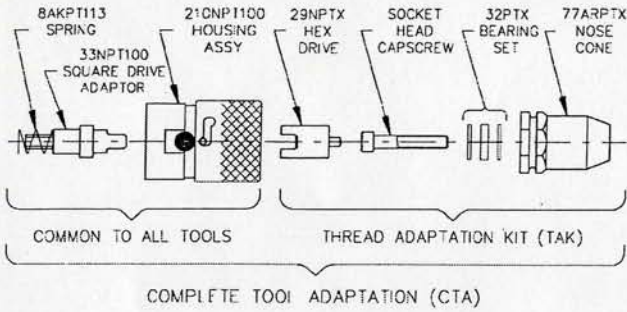

*Knurl only design for AR Series inserts installation-Do not use for AK, AL, AH, AO or AP Series insert installations.

AVK PART NUMBER	TOOL RPM	PARENT MATERIAL	PARENT MATERIAL	COMPLETE TOOL PART NUMBER	THREAD ADAPTION KIT	HEX DRIVE	SCREW MANDREL	BEARING SET	NOSE CONE	DYNAMIC AIR PRESSURE SETTINGS PSI-BARS
		STEEL, ALUMINUM FIBERGLASS, SML	BLW, ROTATIONAL SOFT PLASTICS							
ARS4-420-280	1500	.020-.190	.020-.250	ARPT15P420-280	ARPT420-280TAK	29NPT5	3SH420-2000	32PT5	77NPT 250	60-70
	900	.020-.250	.020-.250	ARPT9P420-280						40-60
ARS4-420-500	1500	.250-.430	.250-.470	ARPT15P420-500	ARPT420-500TAK	29NPT5	3SH420-2250	32PT5	77NPT-250	60-70
	900	.250-.470	.250-.470	ARPT9P420-500						40-60
ARS4-518-280	900	.020-.260	-	ARPT9P518-280	ARPT518-280TAK	29NPT7	3SH518-2500	32PT5	77NPT3125	70-90
	-	-	-	-						-
ARS4-610-7.1	1500	.5-4.8	.5-6.3	ARPT15P610-7.1	ARPT610-7.1TAK	29NPT11	3SH610-50	32PT6	77NPT M6	4.1-4.8
	900	.5-6.3	.5-6.3	ARPT9P610-7.1						2.8-4.1
ARS4-610-12.7	1500	6.3-10.9	6.3-11.9	ARPT15P610-12.7	ARPT610-12.7TAK	29NPT11	3SH610-50	32PT6	77NPT M6	4.1-4.8
	900	6.3-11.9	6.3-11.9	ARPT9P610-12.7						2.8-4.1
ARS4-8125-7.1	900	.5-6.6	-	ARPT9P8125-7.1	ARPT8125-7.1TAK	29NPT12	3SH8125-60	32PT7	77NPT M8	4.8-6.2
	-	-	-	-						-

NOTE: Use high quality alloy steel socket head cap screws such as "UNBRAKO®" by SPS.

A-S SERIES INSERT THREAD ADAPTION KITS AND COMPONENT PART NUMBER

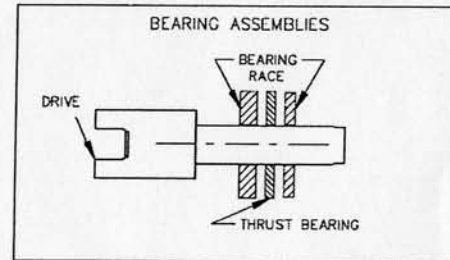
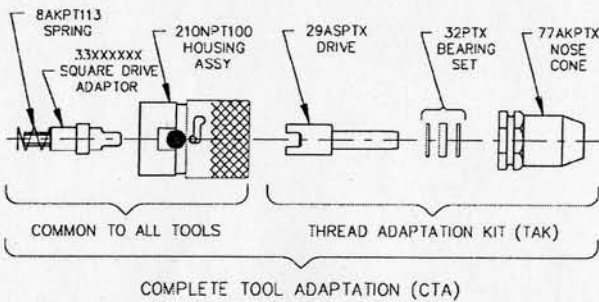

THREAD SIZE	TOOL RPM	COMPLETE TOOL PART NUMBER	THREAD ADAPTION KIT	THREAD DRIVE	BEARING SET	NOSE CONE	SQUARE DRIVE ADAPTOR	DYNAMIC AIR PRESSURE SETTINGS PSI-BARS
632 UNC	3000	ASPT30P632	ASPT632TAK	29ASPT632	32PT5	77ASPT8	33NPT100	70-80
8-32 UNC	3000	ASPT30P832	ASPT832TAK	29ASPT832	32PT5	77ASPT8	33NPT100	75-90
10-24 UNC	1500	ASPT15P1024	ASPT1024TAK	29ASPT1024	32PT12	77ASPT10	33NPT100	60-80
10-32 UNF	1500	ASPT15P1032	ASPT1032TAK	29ASPT1032	32PT12	77ASPT10	33NPT100	60-80
4-20 UNC	900	ASPT9P420	ASPT420TAK	29ASPT420	32PT8	77ASPT4	33NPT100	70-90
5/16-18 UNC	600	ASPT6P518	ASPT518CTA	29ASPT518	30NPT500	77ASPT8125	33PT200	80-110
3/8-16 UNC	600	ASPT6P616	ASPT616 CTA	29ASPT616	30NPT500	77ASPT8125	33PT200	80-110
M4x0,7 ISO	3000	ASPT30P470	ASPT470TAK	29ASPT470	32PT5	77ASPT8	33NPT100	4.8-5.5
M5x0,8 ISO	1500	ASPT15P580	ASPT580TAK	29ASPT580	32PT12	77ASPT10	33NPT100	4.1-5.5
M6x1,0 ISO	900	ASPT9P610	ASPT610TAK	29ASPT610	32PT8	77ASPT4	33NPT100	5.5-6.2
M8x1,25 ISO	600	ASPT6P8125	ASPT8125 CTA	29ASPT8125	30NPT500	77ASPT8125	33PT200	5.5-7.5
M10x1,5 ISO	600	ASPT6P1015	ASPT1015 CTA	29ASPT1015	30NPT500	77ASPT8125	33PT200	5.5-7.5

TROUBLE-SHOOTING

Below are some guidelines for solutions to common setting and tooling problems. By following these steps you should be able to get back into production as quickly as possible if a problem arises:

SCREWS BREAK FREQUENTLY

1. Too much air line pressure. Check the air pressure specs for the thread size you are placing. Adjust downward accordingly.
2. Make sure operator is holding the tool at a 90° angle to the adequate supply of air to the tool.

TOOL STALLS BEFORE FULLY PLACING THE INSERT

1. Be sure there is a bearing assembly in the tool. Check to be sure it is not worn out, and that it is assembled correctly. (see pg. 4 or 5). Clean in solvent, blow dry and *lubricate* with recommended grease. (See tool maintenance section of this manual.)

2. Check for quick disconnect fittings with holes of 1/4" or 3/16". These may be too small to allow the necessary **VOLUME** into the tool. This is especially critical with the 5/16, 3/8 and 1/2 thread size.

3. Be sure the hose I.D. is 5/16".

4. Not enough air line pressure. Check the air pressure specs for the thread size you are placing. Adjust upward accordingly.

5. Check the condition of the drive screw. Replace, if worn using high quality socket head cap screws.

6. Check to see if other air tools are being used that are starving the insert installation tool.

TOOL WILL NOT START/RUN

1. With air system connected, quickly change from forward to reverse several times.

2. Check your air line and air pressure to assure there is an work piece, and not "tilting" it over to one side.

3. Remove the complete tool adaptation kit. Manually rotate rotate the square drive shaft. Connect air to tool and depress trigger.

4. Evaluate airline set-up portion of this manual.

5. If there is an air motor failure, follow instructions in maintenance section of this manual.

AIR MOTOR RUNS, PLACING SCREW DOESN'T

Make sure hex drive is engaged into the socket head cap screw. Check to see if screw is broken or if the head is rounded out. Check also, if the hex drive itself has been rounded off. Replace defective parts as may be required to assure proper installation.

*CALL AVK FOR ADDITIONAL TROUBLE SHOOTING SUGGESTIONS

AIR PRESSURE TROUBLE-SHOOTING: CHECKING SUPPLY AND FITTINGS

If recommended pressures cannot be obtained, the supply system should be checked. Some things to look for are:

1. Inadequate compressor capacity.

2. Improper pipe sizes (I.D. too restrictive).

3. Restrictions caused by fittings with I.D.'s too small. See Note 3 above.

4. Be sure hose and quick disconnect fittings have 5/16" I.D.

5. Shut-off valves. It is best to use stop cock type, which lessen restrictions.

6. Improper coupler and quick disconnect. Use only those with good flow characteristics and assure that they mate correctly.

7. Filter-regulator-lubricator should be compatible, properly sized and maintained.

8. Clogged filter.

*CALL AVK FOR ADDITIONAL TROUBLE SHOOTING SUGGESTIONS

TOOL MAINTENANCE

THRUST BEARING

It is essential that the thrust bearing be lubricated with Lubriplate® #930-AA or equivalent. The thrust bearing and mandrel (socket head cap screws — see pages 4 & 5) are located in the nose cone of the tool. Lubricate as needed, bearing should not run dry. For further details see sections entitled Thread change-over and Disassembly for service (Pages 9-12).

Remove the nose cone & proceed as follows:

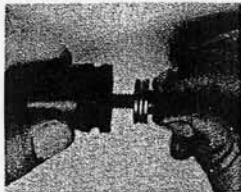

Remove the bearing and socket head cap screw.



Separate the bearing from the races and lubricate. Work grease into bearing. Replace screw if worn. Use only high quality grade 8 screws. See pgs. 4 & 5 for lengths.



Reassemble.

*Lubriplate® is manufactured by Fiske Bros. Refining Co., Lubriplate Division, 129 Lockwood St., Newark, N.J. 07105. Call 973-589-9150 for a Distributor near you.

DISASSEMBLY FOR AIR MOTOR SERVICE

If a problem develops with the air motor, simply disassemble it as shown below and either send the air motor to an ARO service facility or obtain parts from them for repair.



Using a 1 7/16" wrench on the two flats on the housing, unscrew turning clockwise (LH thread), unscrew from tool, and remove the spring and square drive.



Keep these parts separate from the air motor. Send the air motor only to the nearest ARO repair center.

ARO SERVICE FACILITIES

To send a tool motor for repair or to obtain parts, call the appropriate number below. You will be referred to the nearest service facility.

(888) 782-7824

PREVENTIVE MAINTENANCE

HANDLE WITH ORDINARY CARE. A high proportion of tool repairs can be traced to careless handling. In spite of their inherent strength, air tools should not be used as hammers or levers, nor should they be deliberately dropped or dragged along the floor.

LUBRICATION OF GEARED TOOLS. Certain types of air tools contain gearing which should be lubricated regularly with gear grease. Most of these tools have external hydraulic fittings which can be serviced by ARO's Grease Gun #7464-1. Grease 33153 (5 lb. can) for gears and bearings; "O" Ring Lubricant 36460 (4 oz. tube) for lubrication and installation of "O" Rings.

CAUTION: An excessive amount of lubricant in a tool will affect the speed and power. Each set of planetary gearing should contain approximately 1/8 ounce of grease.

FLUSH TOOL with a solution of three parts cleaning solvent and one part light oil after each 40 hours of operation. After flushing, apply a small amount of Spindle Oil in air inlet and run free for one minute to insure proper lubrication.

IF LINE OILER is not used, apply a small amount of Spindle Oil in air inlet of tool and run free for one minute to insure proper lubrication; after each 8 hours of operation.

LUBRICATE DRIVE SCREW. In some applications it may be advisable to dip the first one or two threads of the mandrel into a light oil after several installations to minimize wear.

ARO MOTOR AND GEARING COMBINATIONS FOR PLACING TOOLS

HANDLE STYLE	OLD MOTOR MODEL P/N	NEW MOTOR P/N	RPM	VALVE HOUSING ASSY.	MOTOR ASSY.	AUXILIARY GEARING	DRIVE GEARING	TOTAL REDUCTION
PISTOL	AV3P	8516	350	45463	33816	33837	36324	11.12:1
PISTOL	AV6P	8517	600	45463	33816	33837	36327	8.9:1
PISTOL	AV9P	8518	900	45463	33816	33853	36327	6.8:1
PISTOL	AV15P	8522	1500	45463	33811	—	36329	6.86:1
PISTOL	AV30P	8519	3000	45463	33816	—	36327	3.40:1

ARO AIRMOTOR PARTS AND ASSEMBLY BREAKDOWNS

TYPICAL CROSS-SECTION OF TOOL

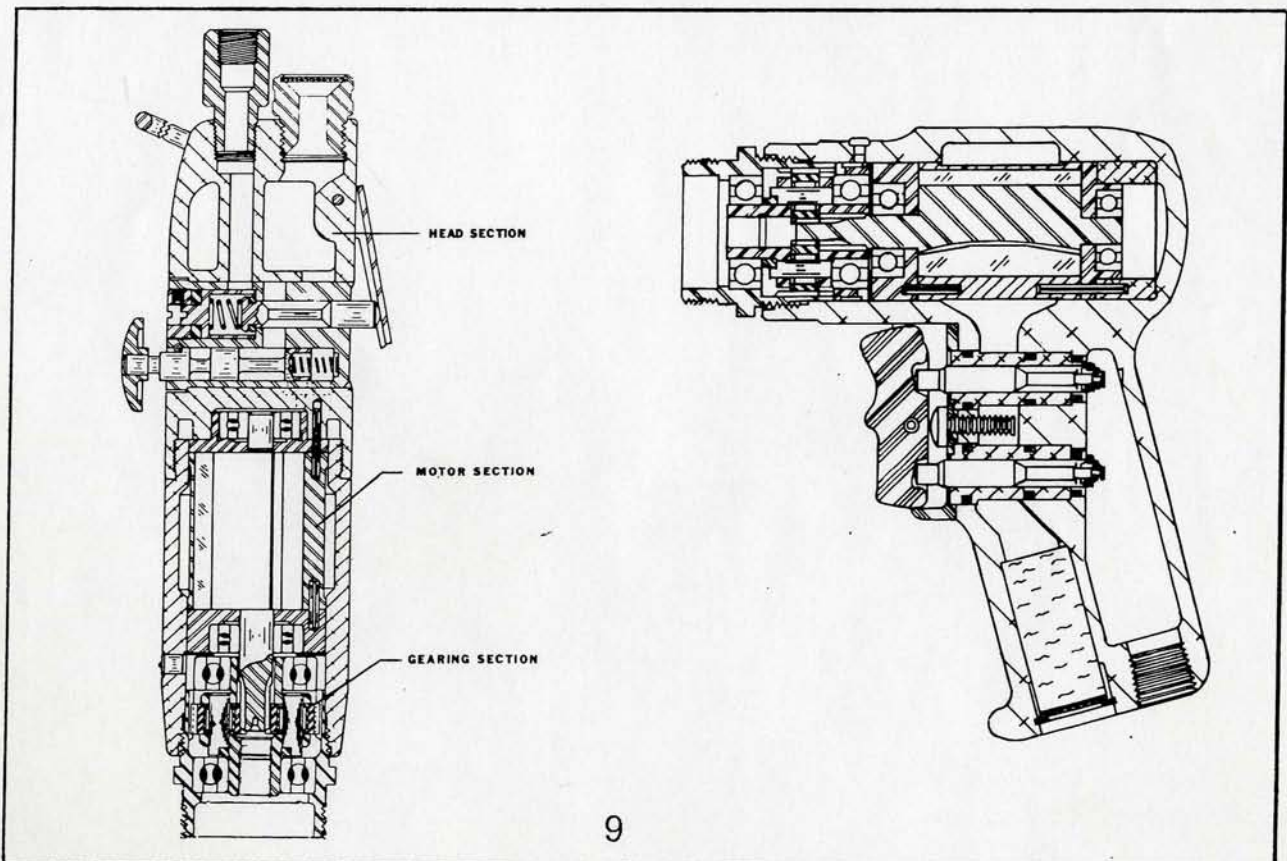

GEARING SECTION DRIVE GEARING

DISASSEMBLY

- a. Remove Spindle and components from Ring Gear.
- b. To remove Gears from Spindle, remove Bearing, Spacer and Shafts.

REASSEMBLY

NOTE: Pack bearings and lubricate gears liberally with 33153 grease or equivalent upon assembly. Gearing assembly should contain approx. 1/8 oz. grease.

- a. Assemble Spacer (33691) or (33693) and Gears to Spindle and secure with Shafts, aligning notch in Shafts with Spacer. NOTE: Shafts (33686) contain fifteen (15) loose Needle Bearings (33458) per shaft.

- b. Assemble Spacer (37676), where applicable, and Bearings to Spindle and assemble to Ring Gear.

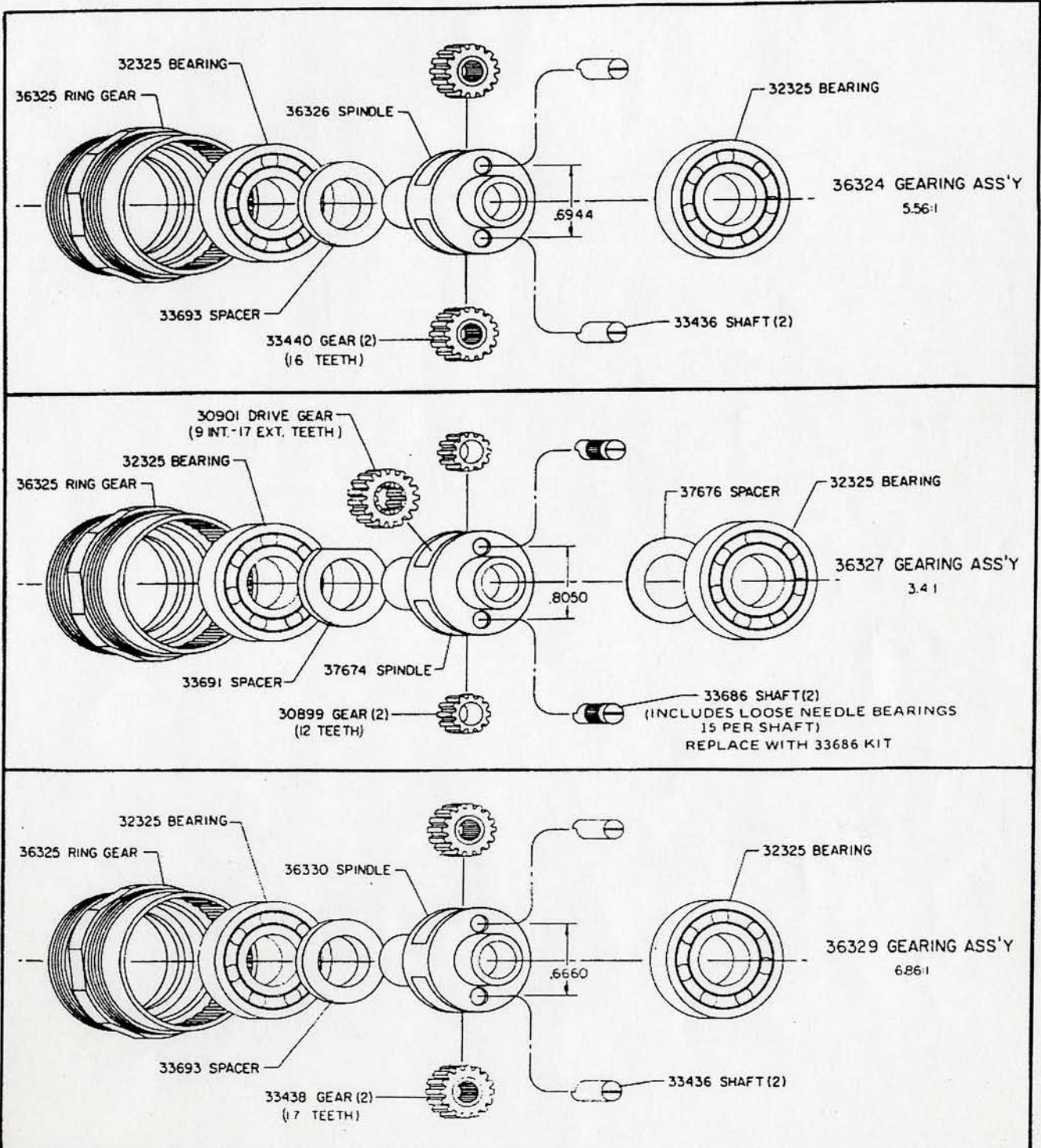

AUXILIARY GEARING

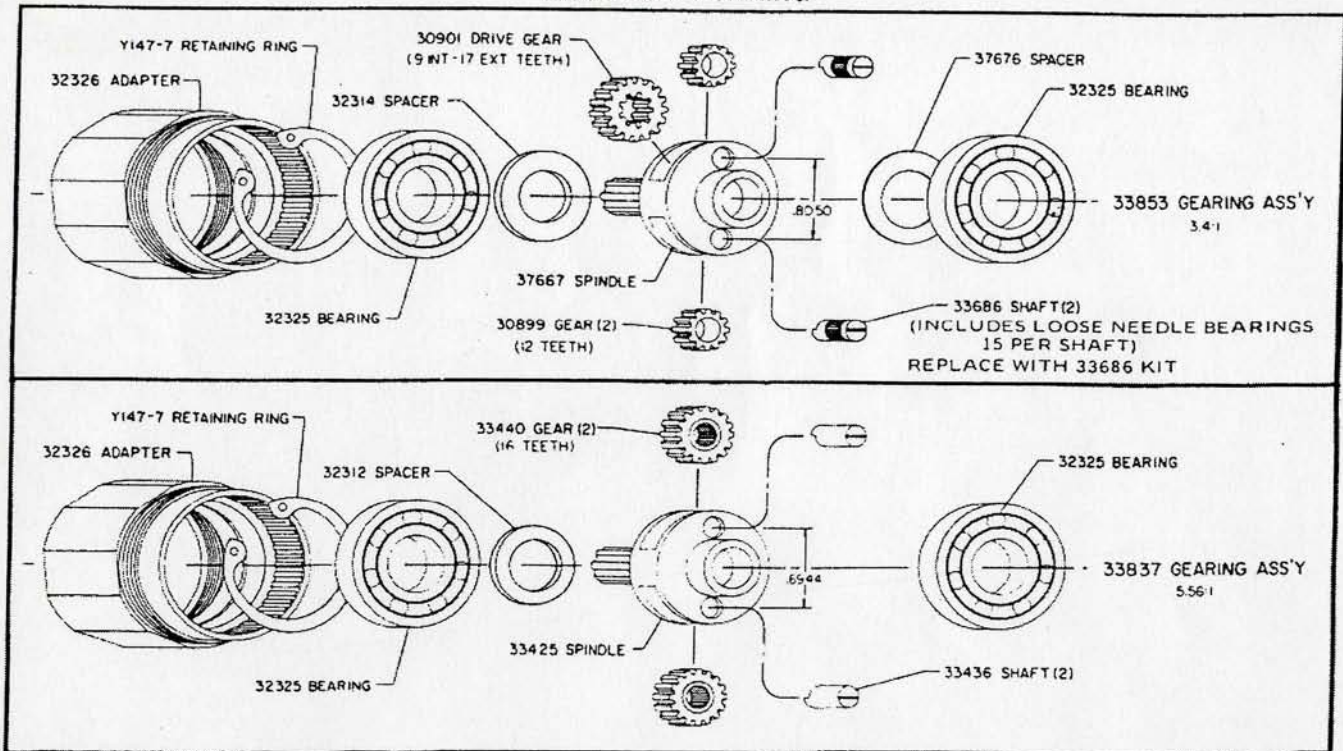

MOTOR SECTION

DISASSEMBLY

- Remove Motor from Housing. Grasp Cylinder in one hand and tap splined end of Rotor with a non-metallic hammer; motor will come apart.

REASSEMBLY

- Pack bearings with grease (33153), or equivalent, and coat I.D. of cylinder with spindle oil upon assembly.
- Assemble Bearings into End Plates and assemble rear End Plate (31601) to Rotor.
- Assemble Cylinder over Rotor to rear End Plate

aligning air inlet holes of Cylinder with air inlet slots of End Plate and assemble Blades into Rotor Slots.

- Assemble front End Plate (31602) to Rotor and Cylinder, aligning Roll Pin in Cylinder with hole in End Plate.
- Insure Rotor does not bind (if Rotor binds, lightly tap splined end with a non-metallic hammer to loosen) and assemble motor to housing with Locating Pin (32814) and Porting Block (45471).
- Assemble Spacer (32310), Spacer (32305) and gearing to tool.

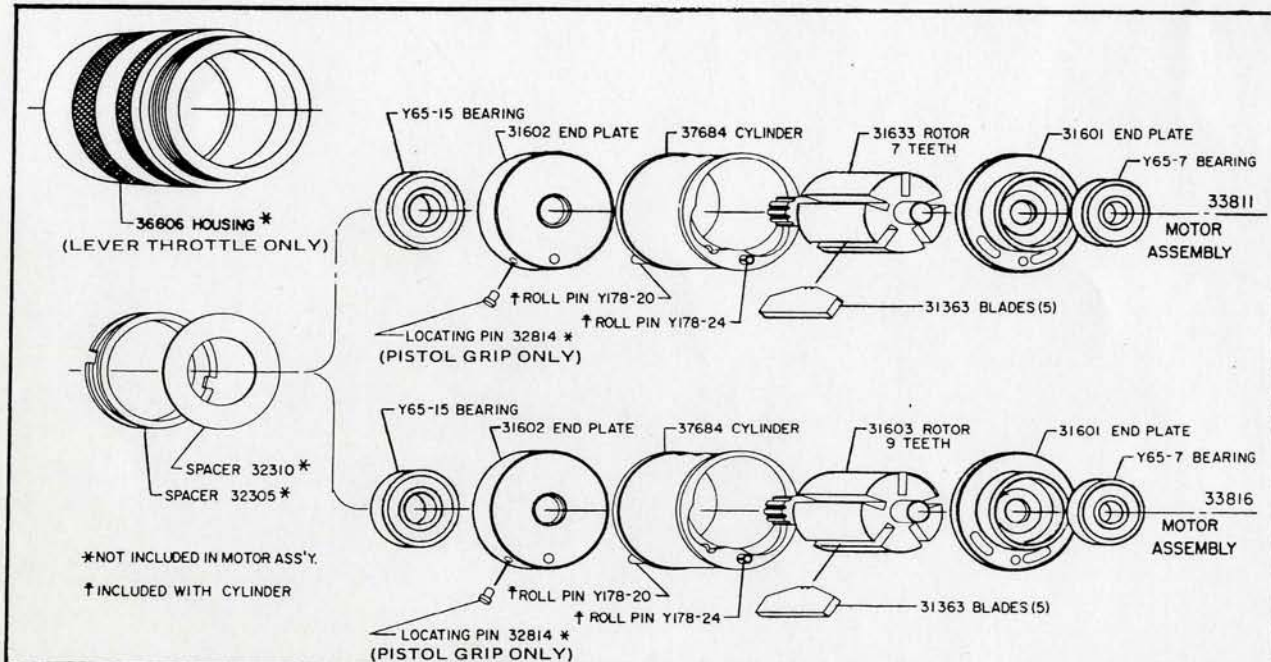

*NOT INCLUDED IN MOTOR ASS'Y.

†INCLUDED WITH CYLINDER

DISASSEMBLY

- a. Remove roll pin (Y178-25), releasing trigger (45469).
- b. Remove screw (Y222-156-C), releasing shroud (45468).
- c. Grasp end of valve assembly (47880) and pull to remove valve assembly and bushing (45465).
- d. Remove retaining ring (Y147-68), releasing screens (42911) and muffler (45474).

REASSEMBLY

NOTE: Whenever a part containing "O" rings has been removed from tool, it is recommended the "O" rings be replaced. Grease all "O" rings before assembly.

- a. Assemble "O" rings (Y325-13, Y325-12 and Y325-11) to bush-

ings (45465).

- b. Assemble "O" ring (Y325-7) to valve assembly (47880).
- c. Lubricate plunger (47879) and valve assembly (47880) with ARO 29665 spindle oil.
- d. Assemble springs (48806-1) to valve assembly (47880).
- e. Assemble plungers (47879) and valve assemblies (47880) to bushings (45465) and assemble bushings to housing, aligning flats of bushings with flats of shroud.
- f. Assemble shroud (45468) to housing, securing with screw (Y222-156-C).
- g. Assemble trigger to shroud, securing with roll pin (Y178-25).
- h. Assemble muffler (45474) and screens (42911) to housing, securing with retaining ring (Y147-68).

